

A Pneumatic Solenoid Valve Primer

by SkeletalRemains

This primer covers the basics of solenoid valves in haunt applications. The valves covered are listed below. All of this knowledge is based on what I have learned in my prop-building experiences.

[intro](#)

[disclaimer](#)

[2 port, 2-way valve / shut-off valve](#)

[3 port, 3-way valve](#)

[4 port, 4-way valve](#)

[5 port, 4-way valve](#)

intro

This is a guide for anyone new to prop-building in haunt applications. This is just a first part that I have put together, which includes valve definition, operation, and application of each. I hope to follow this up with additional guides that go into detail on other aspects as well. I have spent considerable time learning all of this information. I hope that other prop-builders can shortcut this process by reviewing what I have put together here. Comments and questions are welcome!

A Pneumatic Solenoid Valve Primer

by SkeletalRemains

[disclaimer](#)

That's right! DISCLAIMER!

By reading the material on the following pages, you are agreeing that I (the author) is not responsible for your safety in any way and cannot be held responsible for any damage to persons or property that may become injured, harmed, or destroyed, including, but not limited to, death. The articles contained within deal with electricity and compressed air pneumatics, as well as other dangers. Readers are hereby informed that all actions that they take is at their own risk!

Thank you!

-enjoy-

A Pneumatic Solenoid Valve Primer

by SkeletalRemains

2 port, 2-way valve / shut-off valve

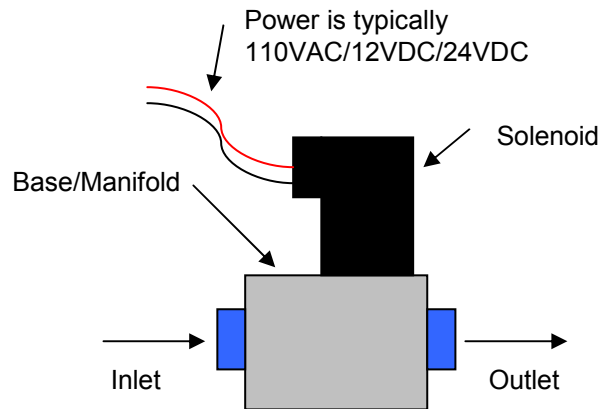

When activated by the solenoid, the valve opens to allow the free flow of liquid, gas, or air, from the inlet to the outlet. This is not typically used with a cylinder, unless the cylinder or airline can rid itself of excess pressure. This is because there is no escape route for pressure. Imagine a balloon connected to the outlet port, it can keep blowing up, but can never reverse flow. These are typically used for air cannons, where pressure is simply vented to the atmosphere and no pressure issues are being dealt with. This is the closest type of solenoid to the washing machine water valves people have been using a lot of recently.

3 port, 3-way valve

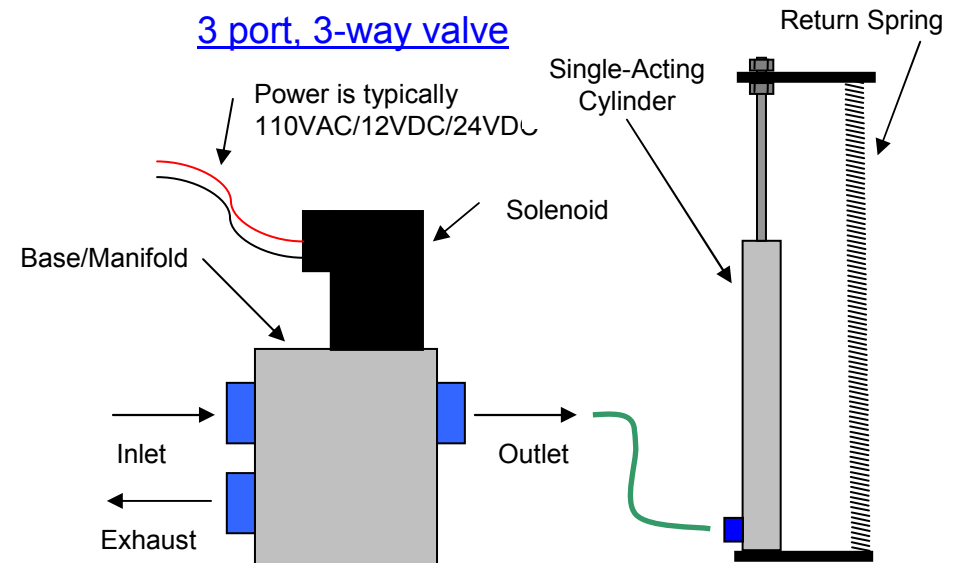

This valve allows the free flow of medium (liquid/gas/air) back through the exhaust when the valve is idle. When activated by the solenoid, the connection is made from the inlet to the outlet, and pressure continues from inlet to outlet. When deactivated, the inlet is closed and air that was pushed into the cylinder now has a way to escape backwards through the exhaust port. However, there is no "pull" on the exhaust port, you must use an alternate method to move your prop mechanism (whatever it is) back to its original starting point. In vertical applications, where the mechanism would just simply "fall back" into its starting position because of gravity, this valve works great. If you have a horizontal application (where gravity doesn't affect it in either position) then you will need a spring for return resistance. If you have a prop where it is actually fighting gravity to reset (like a mechanism that comes down from overhead, and then back up to reset), I wouldn't recommend a 3-way valve.

You can only run single-acting cylinders off of this type, which are cylinders that have only one port on them to actuate the cylinder in a single direction. Single-acting cylinders will only have a single air tube going to them. Now, if you are creative, you can easily use 2 of these 3-way ports and a relay to operate a dual-acting cylinder, but it's just easier to use a 4-way valve for that...

A Pneumatic Solenoid Valve Primer

by SkeletalRemains

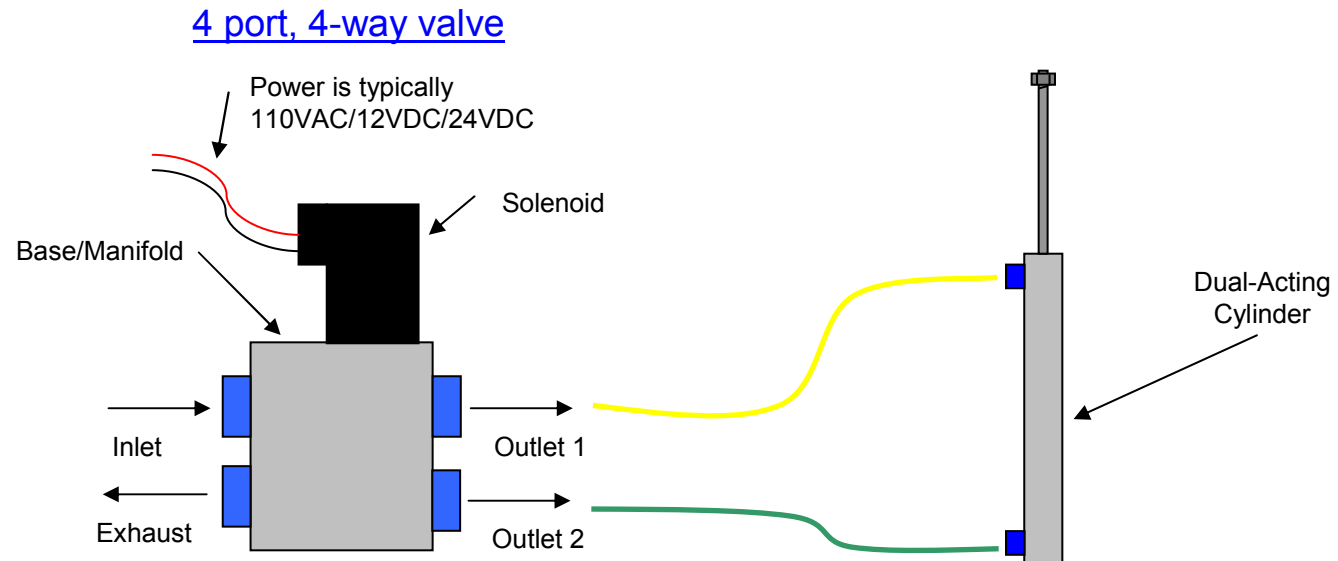

There are actually 2 different types of 4-way valves, and this is the 4-port version. This basically is the same thing as a 3-way valve, with one extra element. Remember on the 3-way valve, it was good for single-acting cylinders, but you had to find a way to reset your prop external of the air circuit (ie: spring, gravity, etc). Well, this 4-way valve solves that problem. The 4-way valve is used on dual-acting cylinders (2 separate airlines going to the cylinder). Essentially, you have a push/pull system with this type of valve. When the valve is idle, the inlet flows straight through to Outlet 1, and Outlet 2 is connected to the exhaust port for free flow of air. When the valve is activated, the connections for the outlets are reversed, and so the air pressure from the inlet is going straight into Outlet 2, and now Outlet 1 is connected to the exhaust, which provides a free flow path for all of the pressure to escape. This is a nice setup, because you can basically mount your prop in any position, without regard to how it will reset, since the cylinder will automatically return to it's original position when the valve is deactivated!

A Pneumatic Solenoid Valve Primer

by SkeletalRemains

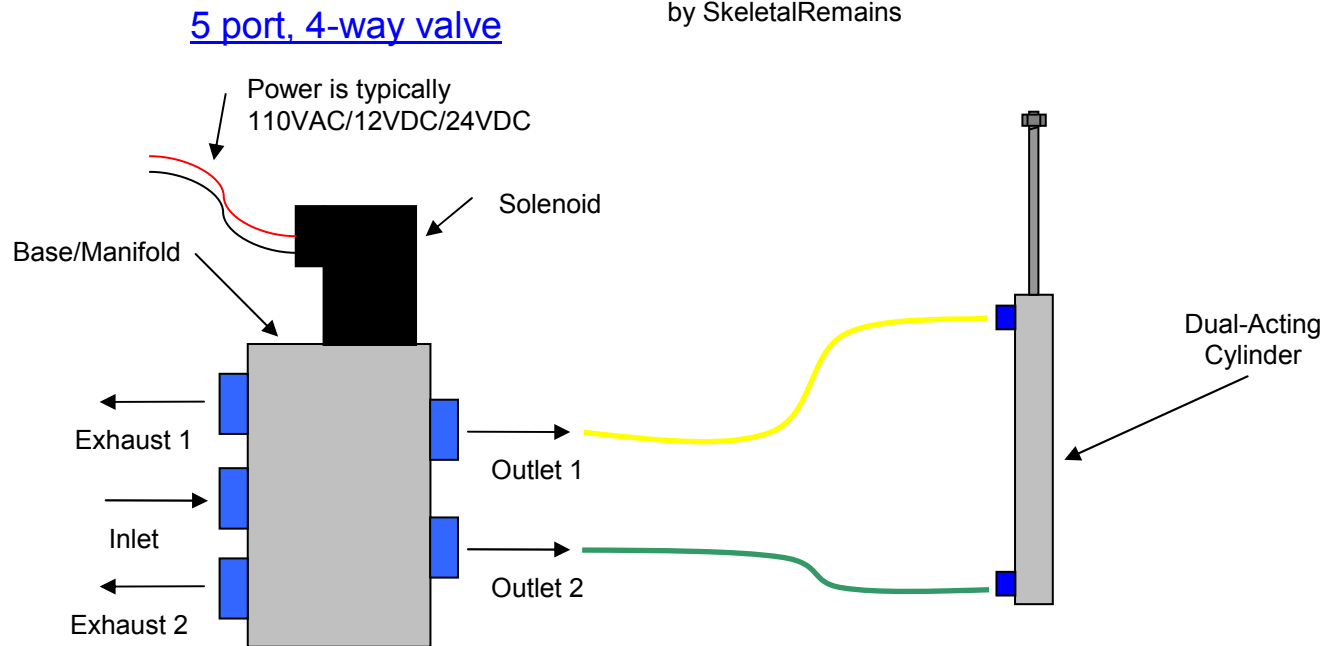

This is the other 4-way valve, the 5-port version. It is my solenoid valve of choice that I like to use everywhere because of its flexibility. The only real difference here between this valve and the 4-port version is that there are 2 exhaust ports. Why on Earth would anyone care if the exhaust ports are combined or separated? Well, let's first look at flow-control, and then we'll come back to that question.

When you apply pressure to a prop, it may jump up too fast, and if you want to slow it down, you introduce a flow-control to reduce air pressure. The flow control can be mid-stream in the air tubing, or it can be integrated into a quick-connect adapter on the cylinder itself. Basically, it simply restricts the flow of air to a certain Cv rate. You can play with the tuning to get your prop jumping at just the right speed. But, when the valve is deactivated, your prop will now reset at the same rate it popped up (because a regular flow control doesn't care which way the air is moving). This could mean that your prop comes up fast, but it might slam down too fast also. After 10 cycles, the prop on the end of your mechanism might fall off or get damaged. The flow control is setting the flow rate for both directions while activating or resetting, regardless of where you put it between the valve and the cylinder. If you only had a way to isolate one path of air, without affecting the other path, you could put the flow control on that path which would result in a fast pop, but a slow reset.

This is exactly what the 5-port, 4-way valve allows you to do. By applying your flow controls to the exhaust ports, you can vary the speed of the mechanism popping and resetting, all at different speeds. Now, I'm sure there are a few people out there who will suggest using a specialty flow-control that restricts flow in one direction, and allows free flow in the other, but I have only ever seen those at very high prices, and it just makes sense to me to pay a few extra dollars for a 5-port valve, instead of paying an extra \$40-\$50 for the specialty flow control. If anyone ever finds those under \$10/each, let me know!